

# OPERABLE WALL (Folding)

**Note:** You will need to purchase the appropriate hardware for your wall conditions.  
Anchors not included.

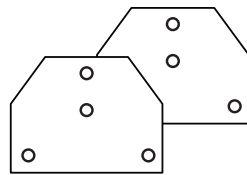

Parts Included

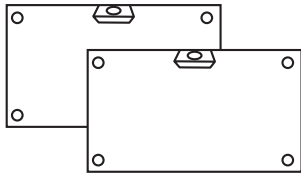
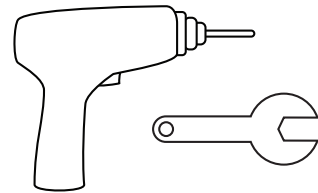

Recommended Tools

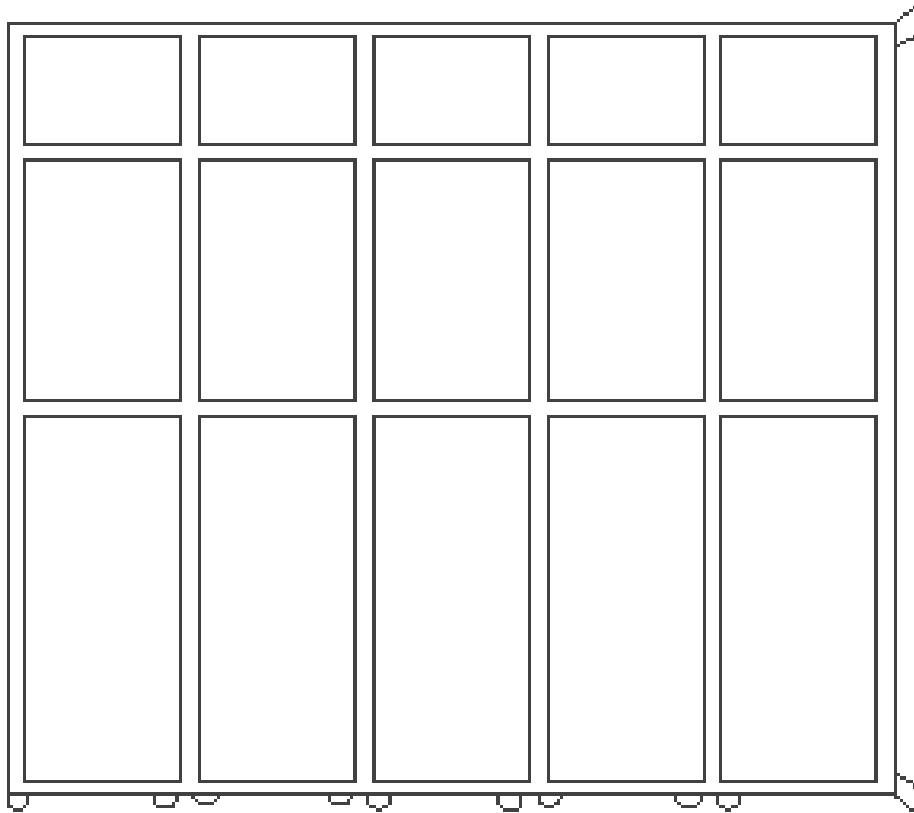

1

Remove screws from bottom panels.

(Top Panels)

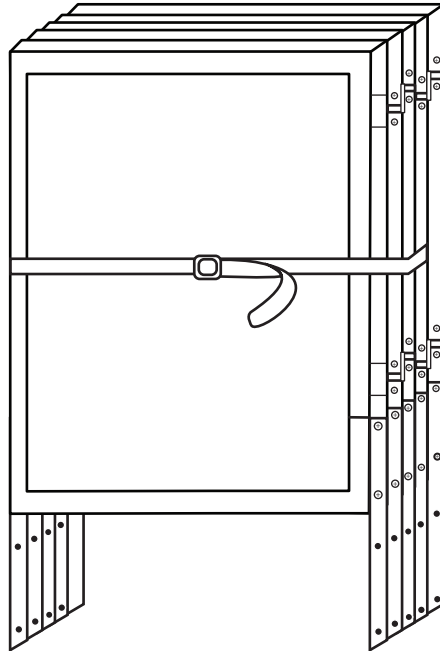

(Bottom Panels)

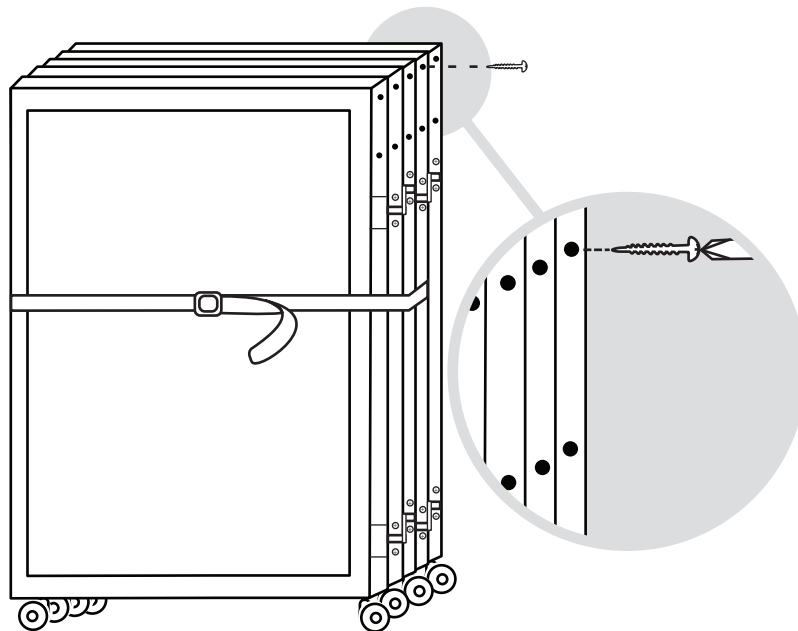

2

Connect top and bottom panels. Then reinsert screws.

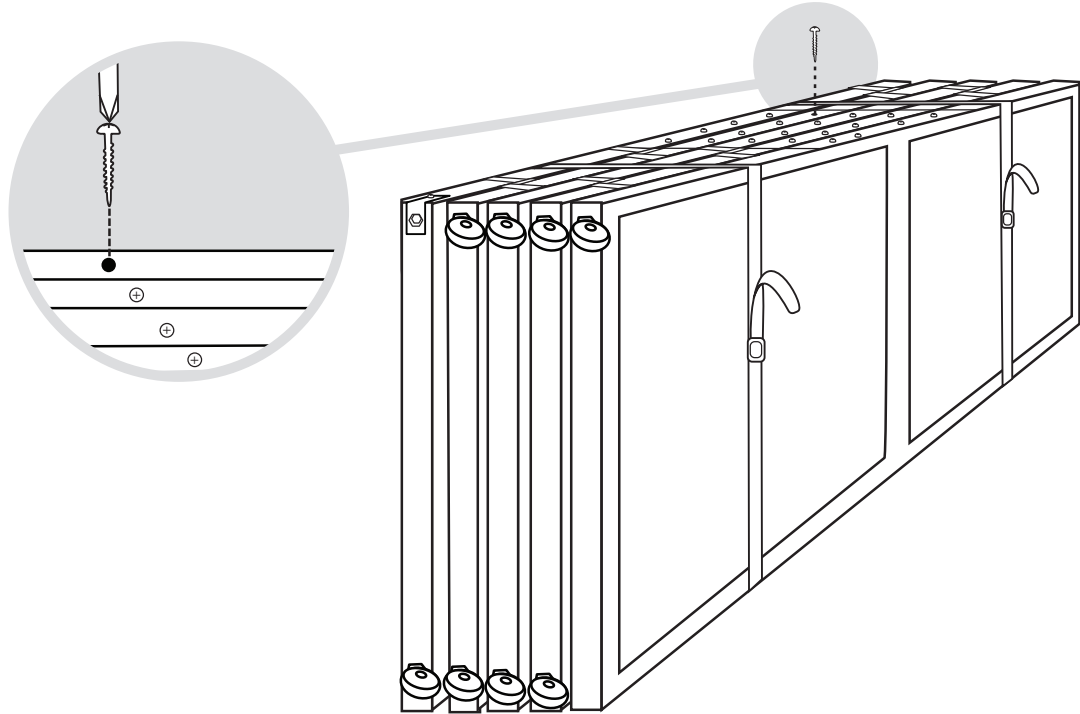

3

Attach wall mount hinges.

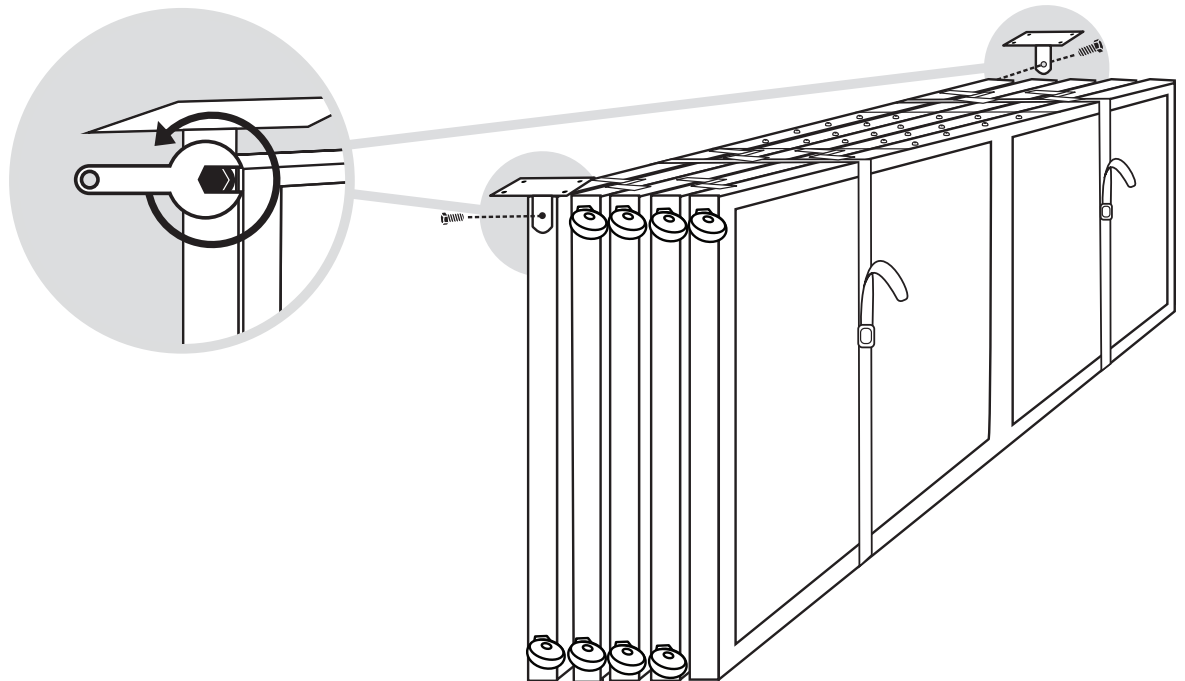

4

Place panels flat on the ground and attach plate loosely to end member panel.

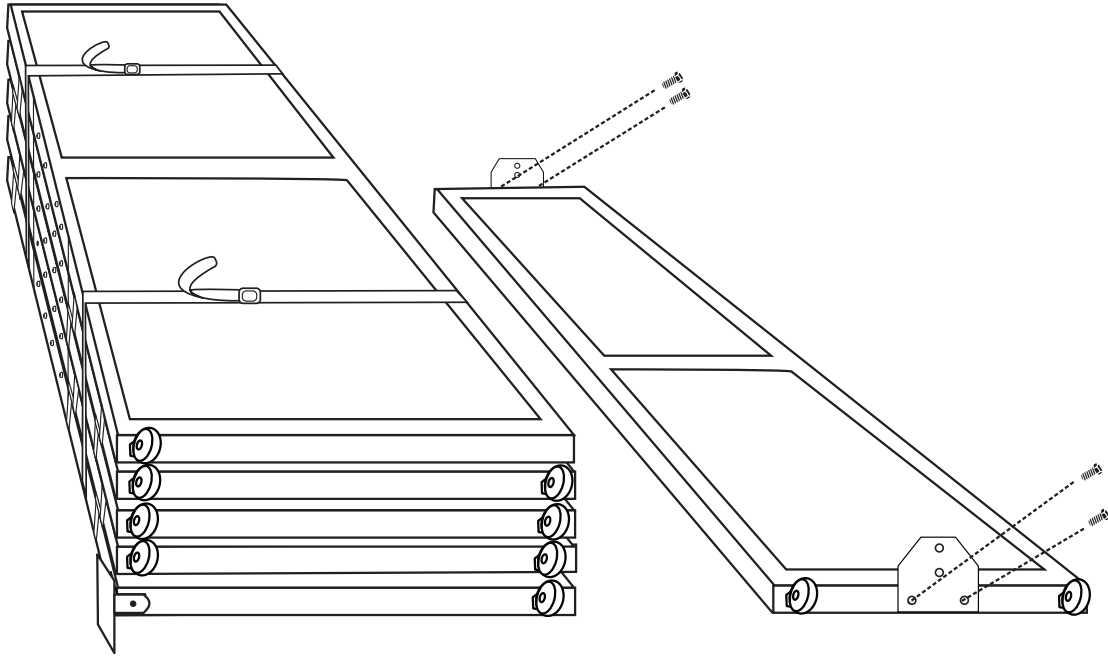

5

Attach end member and plates to the main panels.

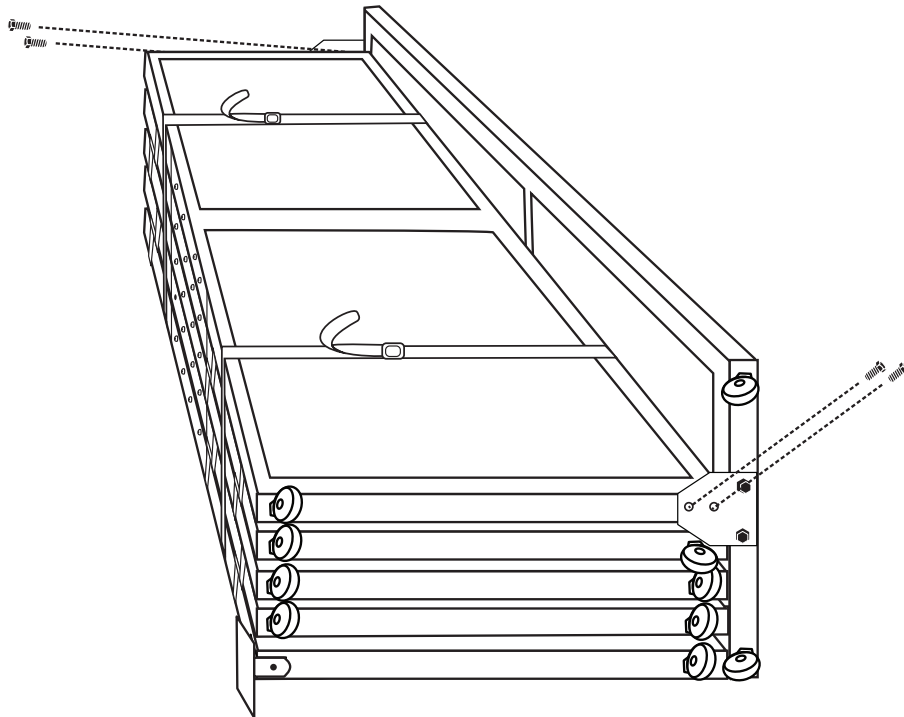

6

Stand up the partition and screw hinges onto wall.

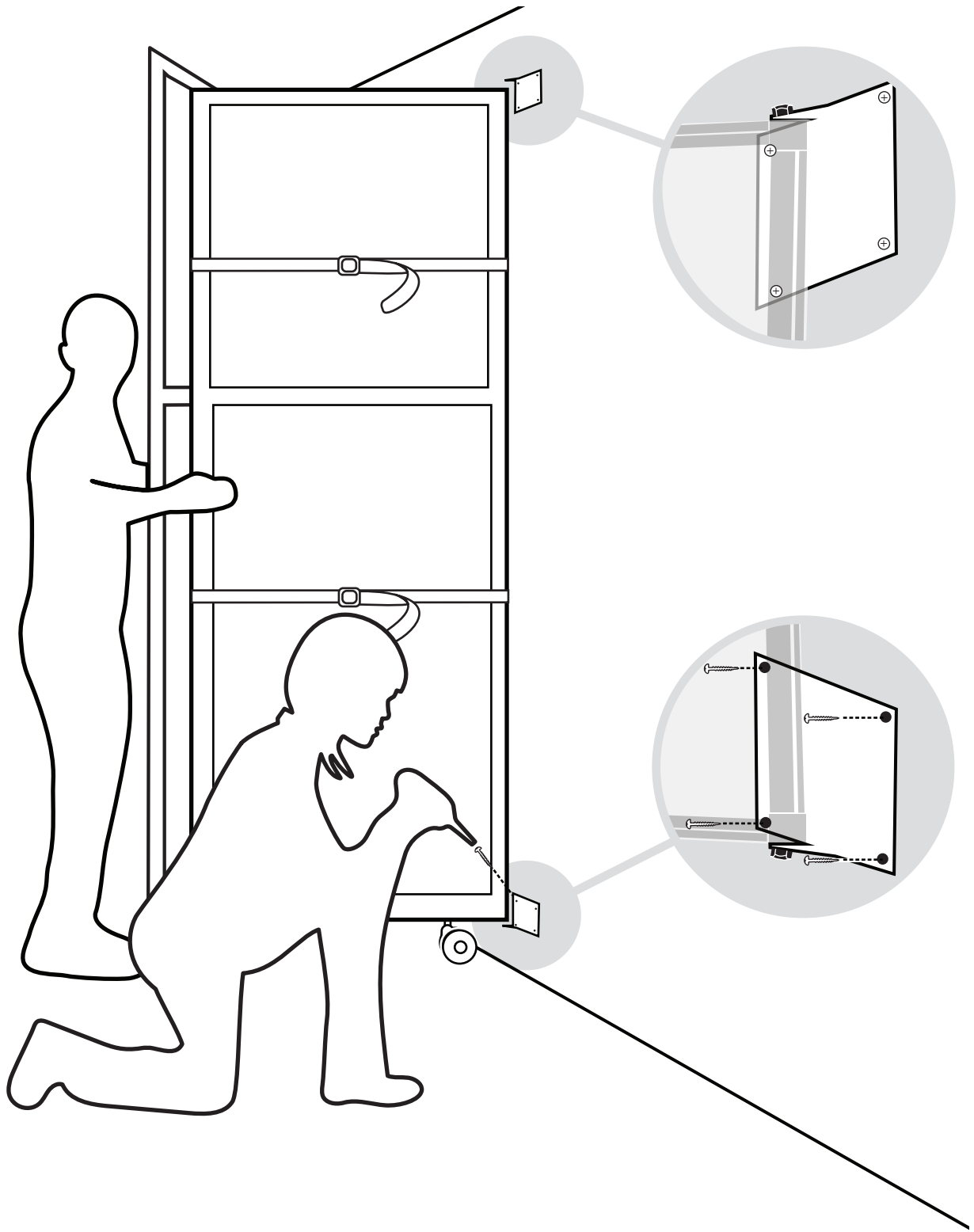

Ph: 09 570 3647

**VERSARE**

[www.versare.co.nz](http://www.versare.co.nz)

10 Rakino Way,  
Mt Wellington

**7**

Unbuckle straps.

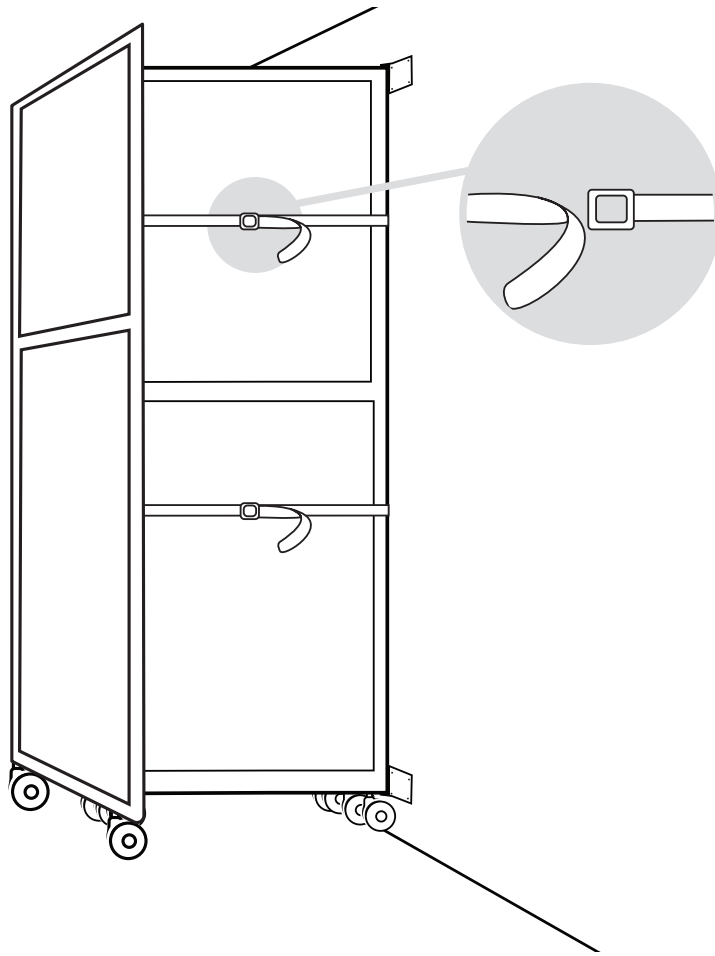

**All complete!  
We hope you enjoy your  
new Operable Wall!**

**If you have any questions on your Operable Wall,  
please contact us at  
09 570 3647 or  
Chris@versare.co.nz**

Ph: 09 570 3647

**VERSARE**  
www.versare.co.nz

10 Rakino Way,  
Mt Wellington