

Remove two bolts. Then attach feet base with **BOLTS FIRST, SCREWS SECOND.**

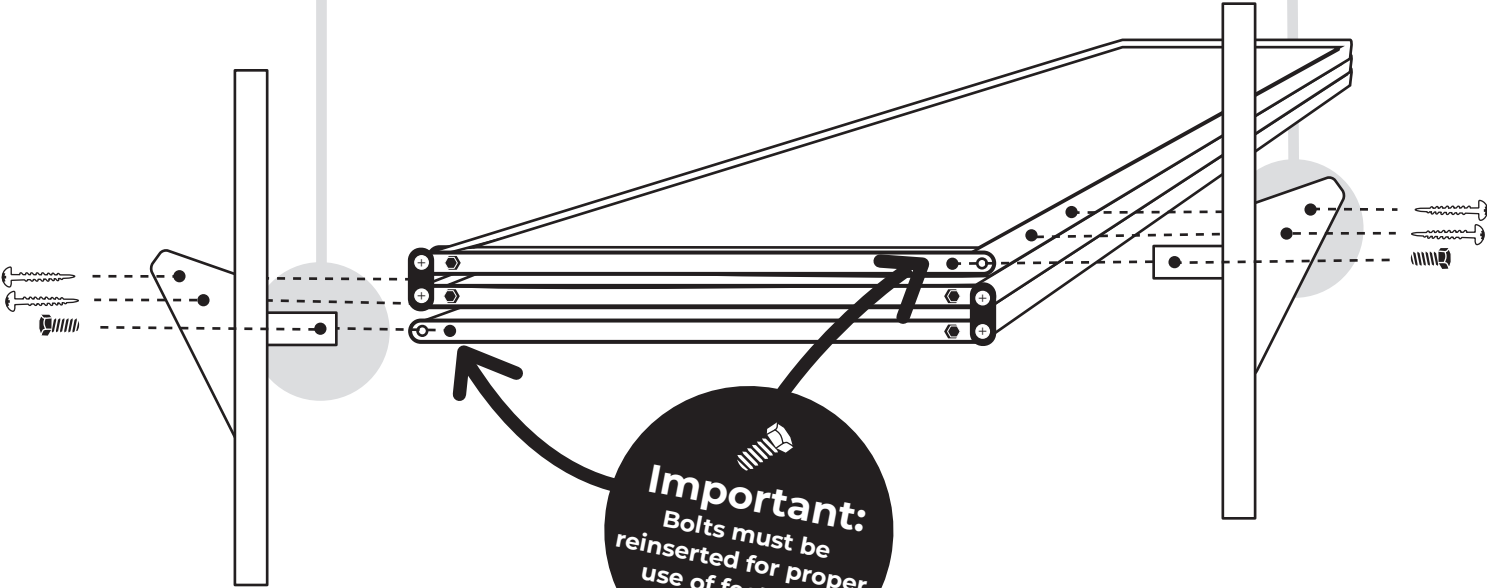

Result:

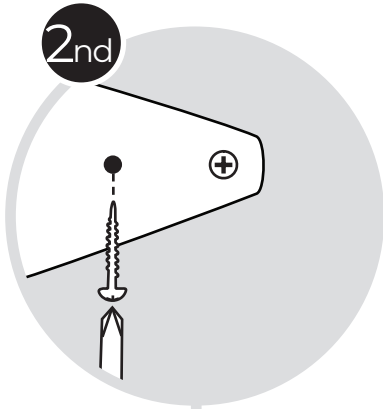
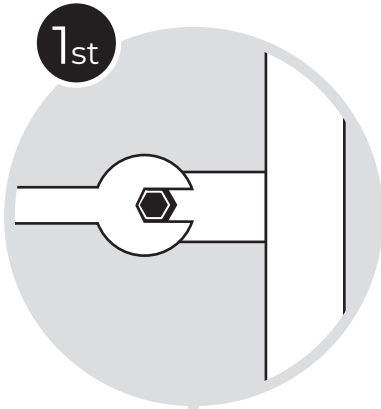
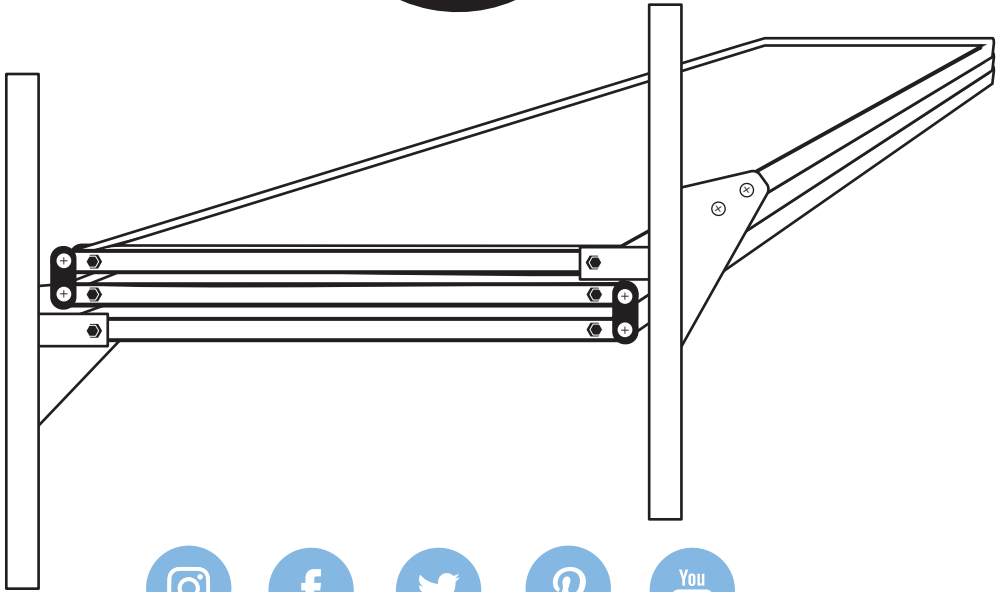

VERSARE
www.versare.com

P: 1.800.830.0210
F: 1.800.310.4874

3236 California St. NE
Minneapolis, MN 55418

QUICK-WALL

(FOLDING)

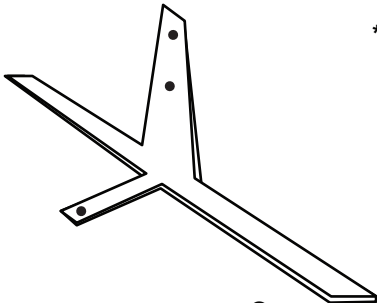

2x

*Screws & bolts arrive attached to partition.



4x



2x

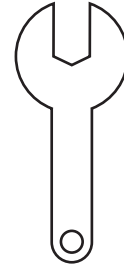

9/16"



Box Contents

Recommended Tools

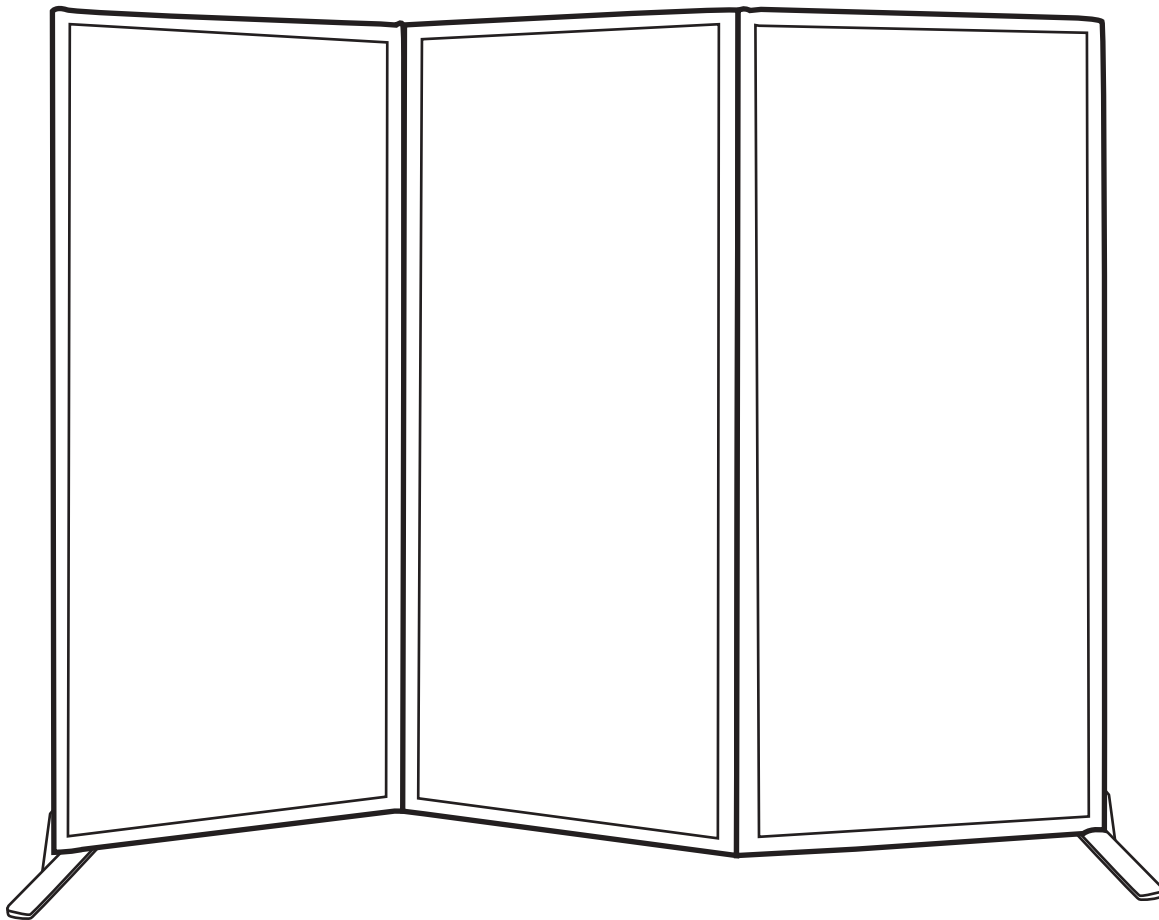

P: 1.800.830.0210
F: 1.800.310.4874

VERSARE

www.versare.com

3236 California St. NE
Minneapolis, MN 55418